

# 規格書

## SPECIFICATION

品名  
STYLE NAME : REDUNDANT SWITCHING POWER SUPPLY

型號  
MODEL NO. : R1S2-5380V4H

料號  
PART NO. :

版次  
REVISION : A2

APPROVE 核准	黃永欣	正式 資料 用 章	
CHECK BY 審核	宋國全		
FORM MAKER 經辦	余嘉豐		

新巨企業股份有限公司  
電源事業處  
ZIPPY TECHNOLOGY CORP.  
POWER DIVISION

## Revision

Rev.	Page	Item	Date	Description
A2	5 7	2.4 4.2.2	SEP-10-2012	Update Inrush current 60/80amps change to 15/30amps Update +12V OVP MAX 15.0V change to 16.0V

# MODEL NO. R1S2-5380V4H

- 1.0 Scope
- 2.0 Input requirements
  - 2.1 Voltage
  - 2.2 Frequency
  - 2.3 Steady-state current
  - 2.4 Inrush current
  - 2.5 Power factor correction
- 3.0 Output requirements
  - 3.1 DC load requirements
  - 3.2 Regulation
  - 3.3 Ripple and noise
    - 3.3.1 Specification
    - 3.3.2 Ripple voltage test circuit
  - 3.4 Overshoot
  - 3.5 Efficiency
  - 3.6 Remote on/off control
- 4.0 Protection
  - 4.1 Input
  - 4.2 Output
    - 4.2.1 OPP
    - 4.2.2 OVP
    - 4.2.3 Short current
- 5.0 Power supply sequencing
  - 5.1 Power on
  - 5.2 Hold up time
  - 5.3 Power off sequence
- 6.0 Signal requirements
  - 6.1 Power good signal
  - 6.2 Under voltage sense level
- 7.0 Environment
  - 7.1 Temperature
  - 7.2 Humidity
  - 7.3 Insulation resistance
  - 7.4 Dielectric withstanding voltage
  - 7.5 Leakage current

8.0 Safety

8.1 UL & UL+C

8.2 TUV

8.3 CB

9.0 Reliability

9.1 Burn in

10.0 Mechanical requirements

11.0 Warning method

11.1 Audio alarm

11.2 Fault LED

11.3 Power defective signal delivery

12.0 DC output cable drawing

1.0 Scope

This specification defines the performance characteristics of a grounded , single-phase , 380 watts , 5 output level power supply. This specification also defines world wide safety requirements and manufactures process test requirements. R1S2-5380V4H power system is a 1+1 Redundant power system consisting of two P1S-2400V-R power modules and one R1S2-5380V4H power system frame.

2.0 Input requirements

2.1 Voltage (sinusoidal)

Full range 100~240 VAC (With ± 10% tolerance)

2.2 Frequency

The input frequency range will be 50Hz/60Hz(±3Hz).

2.3 Steady-state current(Power module)

5.5 – 2.5 amps maximum at any low/high range input voltage.

2.4 Inrush current(Power module)

15 / 30 amps @ 115/230 VAC (at 25 degrees ambient cold start for each power unit)

2.5 Power factor correction

The power supply modules shall incorporate universal power input with active power factor correction, which shall reduce line harmonics in accordance with the EN 61000-3-2 standards.

PFC can reach the target of 95% @230V,full load.

3.0 Output requirements

3.1 DC load requirements

Normal Output voltage	Load current		Regulation tolerance	
	Max.1+1	Min 1+1	Max.	Min.
+5V	20	0.5	+5%	-5%
+12V	30	2.0	+5%	-5%
-12V	0.5	0.1	+10%	-10%
+3.3V	20	0.5	+5%	-5%
+5VSB	2.5	0.1	+5%	-5%

\*\*\* +5V and +3.3V total output max : 140W \*\*\*

\*\*\* Total output max : 380W \*\*\*

\*\*\* When conditions of both+5V/0A & +3.3V/0A, min load of 4A at +12V is a must.

When doing the cross regulation test(one output channel at high load and the other output channels at low load), it is requested to set the higher output channel at 80% max. of its spec., and the lower output channels at 20% max. of theirs.

3.2 Regulation

Output DC voltage	Line regulation
+5V	±50mV
+12V	±120mV
-12V	±120mV
+3.3V	±50mV
+5VSB	±50mV

### 3.3 Ripple and noise

#### 3.3.1 Specification

+5V	50mV (P-P)
+12V	120mV (P-P)
-12V	120mV (P-P)
+3.3V	50mV (P-P)
+5VSB	50mV (P-P)

#### 3.3.2 Ripple voltage test circuit

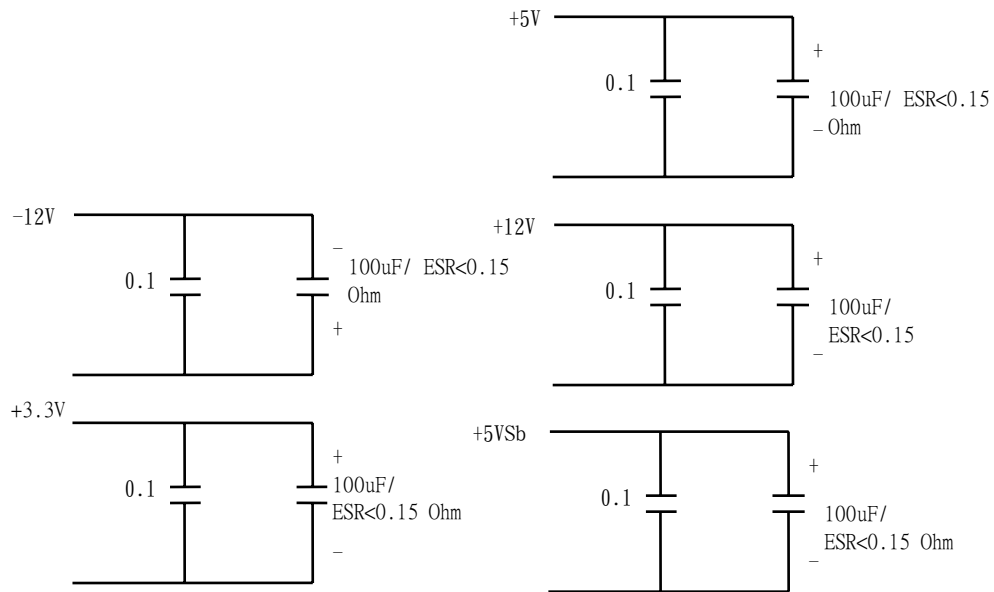

0.1uf is ceramic, the other is electrolytic capacitor.  
Noise bandwidth is from DC to 20Mhz

#### 3.4 Overshoot

Any overshoot at turn on or turn off shall be less than 10% of the nominal voltage value , all output shall be within the regulation limit of section 3.1 before issuing the power good signal of section 6.0.

#### 3.5 Efficiency

Power supply efficiency: 84% (Max)

##### NOTE:

(Any difference either on the DC output cable (i.e., length, wire gauge) or on the accurate of instruments will conclude different test result. It will affects output voltage and efficiency.)

#### 3.6 Remote on/off control

The power supply DC outputs (with the exception of +5VSB) shall be enabled with an active-low , TTL-compatible signal(“PS-ON”)  
When PS-ON is pulled to TTL low , the DC outputs are to be enabled.  
When PS-ON is pulled to TTL high or open circuited , the DC outputs are to be disabled.

## 4.0 Protection

### 4.1 Input (primary)

The input power line must have an over power protection device in accordance with safety requirement of section 8.0

### 4.2 Output (secondary)

#### 4.2.1 Over power protection (one unit)

The power supply shall provide over power protection on the power supply latches all DC output into a shutdown state. Over power of this type shall cause no damage to power supply , after over load is removed and a power on/off cycle is initiated , the power supply will restart.

Trip point total power min. 110% , max. 160%.

#### 4.2.2 Over voltage protection

If an over voltage fault occurs , the power supply will latch all DC output into a shutdown state before

+5V : 5.6V ~ 6.7V

+3.3V : 3.6V ~ 4.3V

+12V : 13.0V ~ 16.0V

#### 4.2.3 Short circuit

A: A short circuit placed on any DC output to DC return shall cause no damage.

B: The power supply shall be latched in case any short circuit is taken place at +5V,+3.3V,+12V,-12V output.

C: The power supply shall be auto-recovered in case any short circuit is taken place at +5VSB.

## 5.0 Power supply sequencing

### 5.1 Power on (see fig.1)

### 5.2 Hold up time

When power shutdown DC output 5V must be maintain 16msec in regulation limit at normal input voltage.

### 5.3 Power off sequence (see fig. 1)

6.0 Signal requirements

6.1 Power good signal (see fig. 1)

The power supply shall provide a "power good" signal to reset system logic , indicate proper operation of the power supply , and give advance warning of impending loss of regulation at turn off. This signal shall be a TTL compatible up level (2.4V to 5.25V) when +5V output voltage are present and above the minimum UV sense levels specified in paragraph 6.2 , or a down level (0.0V to 0.8V) when any output is below its minimum UV sense level.

At power on , the power good signal shall have a turn on delay of at least 100ms but not greater than 500ms after the output voltages have reached their respective minimum sense levels.

6.2 Under voltage (UV) sense levels

Output	Minimum sense voltage
+5V	+4.50V
+3.3V	+2.50V

7.0 Environment

7.1 Temperature

Operating temperature	0 to 40 degrees centigrade
Non-Operating temperature	-20 to 80 degrees centigrade

7.2 Humidity

Operating humidity	20% to 80%
Non-operating humidity	10% to 90%

7.3 Insulation resistance

Primary to secondary	: 100 meg. ohm min. 500 VDC
Primary to Frame Gnd	: 100 meg. ohm min. 500 VDC

7.4 Dielectric withstanding voltage

For approval purpose :

Primary to secondary	: 3KVAC for 1min.
Primary to Frame Gnd	: 1500 VAC for 1 min.

For production purpose: 100% test

Primary to Frame Gnd	: 1500VAC for 1 sec
Cut off current	15mA

7.5 Leakage current

3.5 mA. max. at nominal voltage 250 VAC

8.0 Safety

8.1 Recognized to U.S. and Canadian requirements under the component recognition program of Underwriters Laboratories Inc.  
The power supply shall be designed to meet UL60950.

8.2 TUV Standards

The power supply shall be designed to meet TUV EN-60950.



8.3 CB

The power supply shall be designed to meet CB IEC 60950.

9.0 Reliability

9.1 Burn in

All products shipped to customer must be processed by burn-in. The burn- in shall be performed for 1 hour at full load.

10.0 Mechanical requirements

Physical dimension : 230 mm \* 176 mm \* 41.8 mm (D\*W\*H)

11.0 Warning method

11.1 Audio alarm(buzzer sound,resetable)

11.2 Fault LED

11.3 Power defective signal delivery(TTL,Lowactive)

12.0 DC output cable drawing

(see attached drawing)

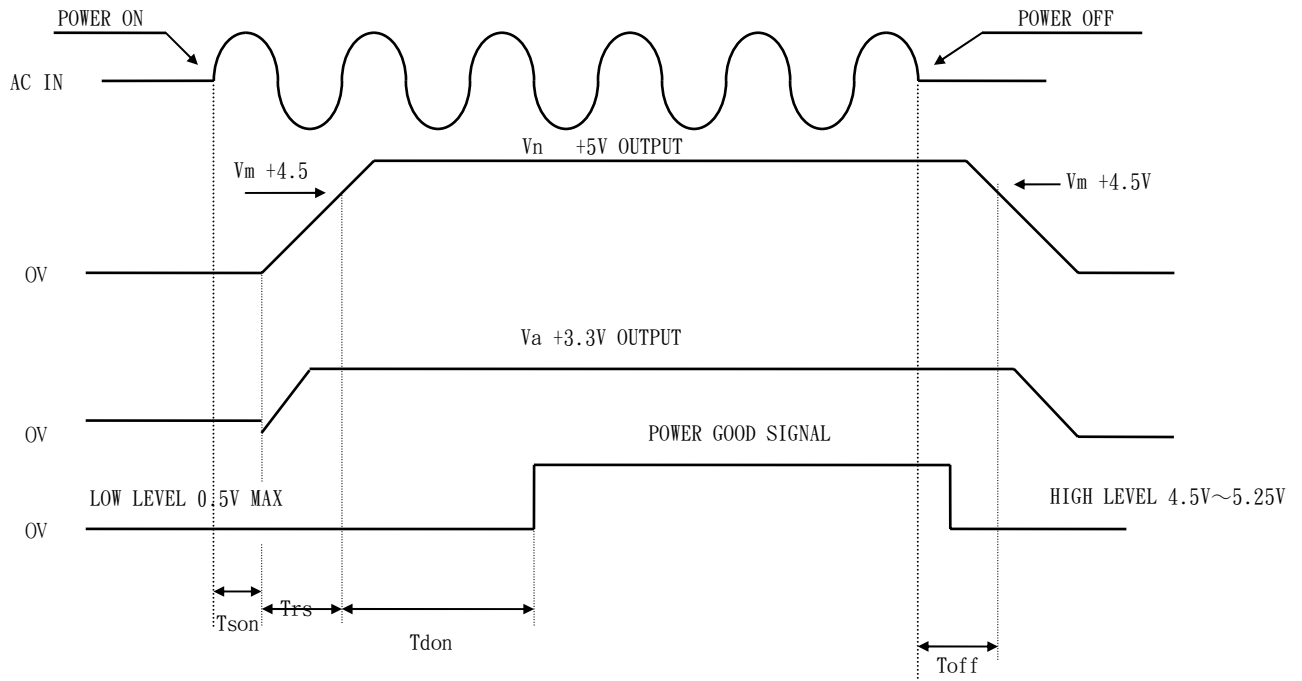

- $V_n$  Nominal voltages +5V
- $V_m$  Minimum voltages +4.5V
- $V_a$  Nominal voltages +3.3V
- $T_{son}$  Switch on time(3000ms. Max)
- $T_{rs}$  +5V rise time (20ms. max.)
- $T_{don}$  Delay turn-on (100ms. <  $T_{don}$  < 500ms.)
- $T_{off}$  Hold up time (16ms. min.)

《Figure 1》