

規格書

SPECIFICATION

品名
STYLE REDUNDANT SWITCHING POWER SUPPLY
NAME :

型號
MODEL NO. : MRZ-5AB0K2V

料號
PART NO. :

版次
REVISION : A2

APPROVE 核准	黃永欣	正 式 資 料 用 章	
CHECK BY 審核	范智高		
FORM MAKER 經辦	曾芳輝		



新巨企業股份有限公司
ZIPPY TECHNOLOGY CORP.

10F, No.50, MINQUAN RD., XINDIAN DIST., NEW TAIPEI CITY 231, TAIWAN
TEL. : +886(2)29188512 FAX. : +886(2)29134969
http://www.zippy.com.tw E-MAIL: powersales@zippy.com.tw



Revision

Rev.	Page	Item	Date	Description
A2	9	3.2	FEB-26-2019	1. Revise +5V and +3.3V total output max → 155W
	14	4.5		2. Revise T _{5VSB_holdup} → 1000Ms
	18	10.1		3. Revise MTBF → 240276



MODEL NO. MRZ-5AB0K2V

1.0 SCOPE

2.0 Input requirements

- 2.1 Volatge/Current/Frequency
- 2.2 Power Factor and i-THD
- 2.3 Power Factor Correction
- 2.4 Power Factor Correction
- 2.5 Efficiency
- 2.6 Leakage Current
- 2.7 Inrush Current
- 2.8 AC Line dropout
- 2.9 AC Line Disturbance
- 2.10 AC Line Fuse

3.0 Output requirements

- 3.1 Output Volatge
- 3.2 Output Current
- 3.3 Load Transient Response
- 3.4 Output Ripple Noise
- 3.5 Capacitive Loading
- 3.6 Hot Swap Requirement

4.0 Control and Signal

- 4.1 PSON#
- 4.2 I2C
- 4.3 LED Marking and Identification
- 4.4 Internal Cooling FAN
- 4.5 Timing
- 4.6 Report Accuarcy

5.0 Output Ptotection

- 5.1 Over Current Protection(OCP)
- 5.2 Over/Under Voltage Protection(OVP/UVP)
- 5.3 Short Circuit Protection(SCP)
- 5.4 Over temperature Protection(OTP)

6.0 Environment Specification

- 6.1 Temperature
- 6.2 Humidity
- 6.3 Altitude

7.0 EMI

- 7.1 Conducted emission
- 7.2 Radiated emission
- 7.3 Harmonic Current

8.0 EMS

- 8.1 Electrostatic Discharge (ESD)
- 8.2 Radiated Immunity (RS)
- 8.3 Transient Burst (EFT)
- 8.4 Surge
- 8.5 Conducted Radio Frequency Disturbances Test (CS)
- 8.6 Power Frequency Magnetic Field Test
- 8.7 Voltage Dips, Short Interruptions and Voltage Variations

9.0 Safety

- 9.1 Safety Conforming
- 9.2 Insulation Resistance
- 9.3 Dielectric Strength (Hi-Pot)
- 9.4 Reliability

10.0 MTBF

11.0 Mechanical requirements

1.0 Scope

This specification defines the performance characteristics of a grounded, Ac input, 1200 watts, 5 output level power supply. This specification also defines world wide safety requirements and manufactures process test requirements.

MRZ-5AB0K2V power system is a 1+1 redundant power system consisting of two ZRH-2AB0K2 power modules and one MRZ-5AB0K2V power system frame.

2.0 Input requirements

2.1 Volatge/Current/Frequency

The power supply should be able to meet all output specifications for any combination of voltages and frequencies described in Table-1. The power supply is expected to meet all output specifications with a UPS using an approximated sine wave with less than 10% THD. Correct operation with a square wave output UPS is desired.

This power supply will operate between 264-300Vac without substantial degradation in reliability with an applied input voltage of 300Vac for a duration of 1 minute minimum.

The power supply unit shall be capable of start-up with full rated load at all line condition and all operating ambient temperature condition.

Table-1 AC Input Operation Rating

Parameter	Description		
	Min	Typ	Max
Vin(High Line)	180Vac	220Vac (200~240Vac)	264Vac
Vin(Low Line)	90Vac	110Vac (100~127Vac)	<180Vac
Input Frequency	47Hz	50/60Hz	63Hz
Max Input Current(High Line)	9A	8A	--
Max Input Current(Low Line)	12A	10A	--
Vin Brown in level	81Vac	85Vac	89Vac
Vin Brown out level	70Vac	75Vac	80Vac

2.2 Power Factor and i-THD

Table-2 PF/i-THD Value

Parameter	Description			Condition
	Min	Typ	Max	
PF 1	0.99	--	--	Vin = 230Vac, Input Frequency = 50 / 60 Hz Output Load = 100%
PF 2	0.98	--	--	Vin = 230Vac, Input Frequency = 50 / 60 Hz Output Load = 50%
PF 3	0.96	--	--	Vin = 230Vac, Input Frequency = 50 / 60 Hz Output Load = 20%
PF 4	0.9	--	--	Vin = 230Vac, Input Frequency = 50 / 60 Hz Output Load = 10%
Parameter	Description			Condition
	Min	Typ	Max	
i-THD 1	--	--	5%	Vin = 230Vac, Input Frequency = 50 / 60 Hz Output Load = 100%
i-THD 2	--	--	8%	Vin = 230Vac, Input Frequency = 50 / 60 Hz Output Load = 50%
i-THD 3	--	--	15%	Vin = 230Vac, Input Frequency = 50 / 60 Hz Output Load = 20%
i-THD 4	--	--	20%	Vin = 230Vac, Input Frequency = 50 / 60 Hz Output Load = 10%

2.3 Power Factor Correction

The power supply shall have Power Factor Correction meeting EN 61000-3-2, EN 61000-3-3, IEC 1000-3-2, IEC 1000-3-3, IEC 555-2, and CENELEC EN 60555-2 under all conditions. The boost power factor (PFC) circuit shall protect against bulk capacitor over-voltage due to boost control circuit failure. When a boost over voltage condition is detected, the output +12VDC shall be turned off and the PFC shall be shut down or operate in latch off mode.

2.4 Power Factor Correction

The AC input receptacle shall be an IEC-320 type C14 capable of at least 15A at 120Vac rating and 10A at 250Vac rating. This connector is located at the front side of power supply. There is a retainer to fix the line cord to avoid accident disconnection.

2.5 Efficiency

The minimum power supply system efficiency shall be $\geq 86\%$, measured at nominal input voltage 230 V and full loading(one power unit).

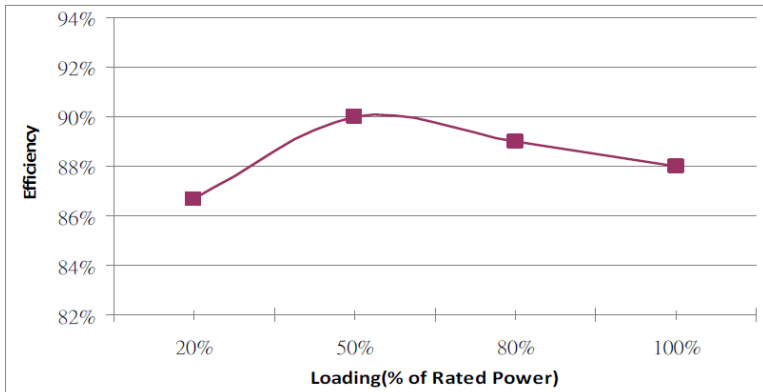

NOTE:

The different harness conditions and/or the accuracy of measurement instruments affect the test result of output voltage and efficiency.

Harness conditions are such as cable length, wire gauge, the connector types and with fan loss, total harness amounts.

2.6 Leakage Current

The leakage current at 240Vac/60Hz shall not be over 3.5mA.

2.7 Inrush Current

The power supply must meet "cold start inrush current" requirements for any combination of input voltages and frequencies described in Table-1 and over the specified temperature range. During a single cycle AC dropout condition or during repetitive ON/OFF cycling of AC, the power supply unit must not damage.

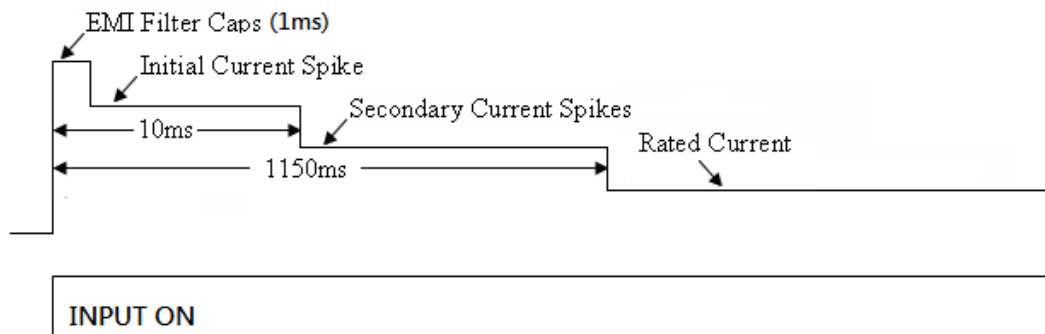

Note:

(1) Due to input line filter charging, the inrush current is ignored during 0~1msec after AC power turn on.

- (2) Peak inrush current at any allowable operating temperature shall not open line fuse/breaker, or cause damage to the power supply unit.
- (3) The cold start inrush current during 1~1150ms or less will not exceed 35A peak.
- (4) The Warm start inrush current during 1~1150ms or less will not exceed 35A peak.

2.8 AC Line dropout

An AC power dropout is the condition when AC power drops to 0 at any phase for any length of time. During an AC power dropout, the power supply unit must meet voltage regulation requirements. An AC power dropout of any duration shall not cause any malfunction. If the AC power dropout is longer than hold up time, the power supply should recover and meet all turn on requirements. The power supply shall meet the AC dropout requirement over AC voltages and frequencies in section 2.1, over the loading condition in section 3.2, capacitive load in section 3.5 and temperature specification in section 6.0. A dropout of the AC line for any duration shall not cause damage to the power supply.

Table-3 AC Line dropout

	Loadind during AC dropout	5VSB Holdup time/Dropout duration
5VSB	100% of rated load	70ms minimum

	Loadind during AC dropout	+12VDC Holdup time/Dropout duration
+12VDC	70% of rated load	10ms minimum

2.9 AC Line Disturbance

The following requirements should be over the complete load, temperature of the power supply unless specified otherwise.

Table-4 AC Line Sag

Duration	Sag	Input Voltage	Input Frequency	Performance Criteria
0~1/2 cycle	95%	Nominal AC	50/60Hz	No loss of function or performance.
> 1 AC cycle	>30%	Nominal AC	50/60Hz	Loss of function acceptable, self recoverable.

Table-5 AC Line Swell

Duration	Swell	Input Voltage	Input Frequency	Performance Criteria
Continous	10%	Nominal AC	50/60Hz	No loss of function or performance.
0~1/2 cycle	30%	Nominal AC	50/60Hz	No loss of function or performance.

Note: During those testing as above, the load should be set to maximum and minimum.

2.10 AC Line Fuse

A normal-fast-blow and high-breaking-capacity fuse must be placed in the single line fuse on the hot wire of the AC input. AC inrush does not cause the AC line fuse to blow under any condition. All protection circuits in the power supply do not cause the AC fuse to blow unless a component in the power supply has failed. AC/DC line fuse must be acceptable for all safety agency requirements.

3.0 DC Output requirements

3.1 Output Volatge

The power supply output voltages must stay within the following voltage limits when operating at steady state and dynamic loading conditions. The +12V is measured at its remote sense signal +12VS located at the signal connector

Table-6 Output Voltage Regulation

Output Voltage	+5V	+3.3V	+12V	-12V	+5VSB
Load Reg.	±5%	±5%	±5%	±10%	±5%
Line Reg.	±1%	±1%	±1%	±1%	±1%

3.2 Output Current

Table-7 Output Current Rating

Output	+5V	+3.3V	+12V	-12V	+5VSB
Max. Load	20A	20A	100A(high line) 66.7A(low line)	0.5A	3.5 A
Min. Load	0A	0A	0A	0A	0A

(1) +5V and +3.3V total output max : 155W

(2) Total power :1200W (high line) / 800W(low line)

3.3 Load Transient Response

The output voltages shall remain within the limits specified in Table 7 for the step loading and within the limits specified in Table 8 for the capacitive loading. The load transient repetition rate shall be tested between 50Hz and 5kHz at duty cycle ranging from 10%-90%. The load transient repetition rate is only a test specification. The Δ step load may occur anywhere within the MIN load to the MAX load range.

Table-8 Load Transient

Output Voltage	Δ STEP LOAD SIZE	Load Slew Rate	Capacitive Load
3.3V	30% of Max Load	0.5A/ μ s	1000 μ F
+5V	30% of Max Load	0.5A/ μ s	1000 μ F
+12V	50% of Max Load	0.5A/ μ s	2200 μ F
+5VSB	25% of Max Load	0.5A/ μ s	1 μ F

Note: For dynamic voltage regulation requirements +12V min Loading is 1A.

3.4 Output Ripple Noise

Maximum allowed output ripple noise of the power supply unit is defined in below table with minimum capacitive loading at all specified input voltage condition, all specified output load and any operating environmental requirement.

Measurements will be made with an oscilloscope set to 20MHz bandwidth limit. Connected the probe with the input tip and ground as short as possible. The decoupling capacitor are 10uF tantalum capacitor in parallel with 0.1uF ceramic capacitor.

Table-9 Output Ripple Noise

Output Voltage	Maximum	Unit
+5V	50	mV
+12V	120	mV
-12V	120	mV
+3.3V	50	mV
+5Vsb	50	mV

3.5 Capacitive Loading

The PSU will be able to power up and operate normally with the capacitive load on the DC output. The power supply shall be stable and meet all requirements with following capacitive loadings.

Table-10 Capacitive Loading

Output Voltage	MIN	MAX	Units
3.3V	10	12000	μF
+5V	10	12000	μF
+12V	10	11000	μF
-12V	1	350	μF
+5VSB	1	350	μF

3.6 Hot Swap Requirement

Hot swapping a power supply is the process of inserting and extracting a power supply from an operating power system. During this process the output voltages shall remain within the limits with the capacitive load specified. The hot swap test must be conducted when the system is operating under static, dynamic and zero loading conditions. The power supply shall use a latching mechanism to prevent insertion and extraction of the power supply when AC power cord is inserted into power supply.

4.0 Control and Signal

4.1 PSON#

The PSON signal is required remotely to turn on/off the power supply. PSON is an active low signal that turns on the 12VDC power rail. When this signal is not pulled low by the system, or left open, the 12VDC turn off. The power supply shall provide an internal pull-up to TTL high. The power supply also provide de-bounce circuitry on PSON to prevent it from oscillating On/Off at startup when activated by mechanical switch.

Table-11 PSON Signal Characteristic

Signal type	Accepts an open collector/drain input from the system. Pull-up to VSB located in power supply.	
PSON=Low	on	
PSON=high	off	
	Minimum	Maximum
Logic level low voltage	0V	1V
Logic level high voltage	2V	3.46V
Source current, Vpson = low		4mA
Power up delay: Tpson_on_delay	5ms	400ms
PWOK delay: T pson_pwok		50ms

4.2 I2C

This power supply supports both I2C function and PMBus 1.2. With different addressing, the user should able to use either I2C FRU or PMBus commands. Please refer to firmware specification for PMBus application profile.

4.3 LED Marking and Identification

The power supply is using a bi-color LED: Amber and Green for status indication. Below are table showing the LED states for each power supply operating state.

Table-12 LED Status

Power Supply Condition	LED State
Output ON and OK.	Solid Green
No AC power to all power supplies.	OFF
AC present/Only 5VSB on(PS off) or PS in Cold redundant state.	1Hz Blink Green
AC cord unplugged or AC power lost; with a second power supply in parallel still with AC input power.	Solid Amber

Power supply warning events where the power supply continues to operate; high temp, high power, high current, slow fan.	1Hz Blink Amber
Power supply critical event causing a shutdown; failure, OCP, OVP, Fan fail.	Solid Amber

4.4 Internal Cooling FAN

Power supply unit shall use 40mm x 40mm high-speed 12V input fan. Detection circuits shall be included such that an open or blocked rotor condition shall cause the +12VDC to shut down according to firmware. Fan fault detect circuit shall delay to response about 10~15 seconds of ignore time.

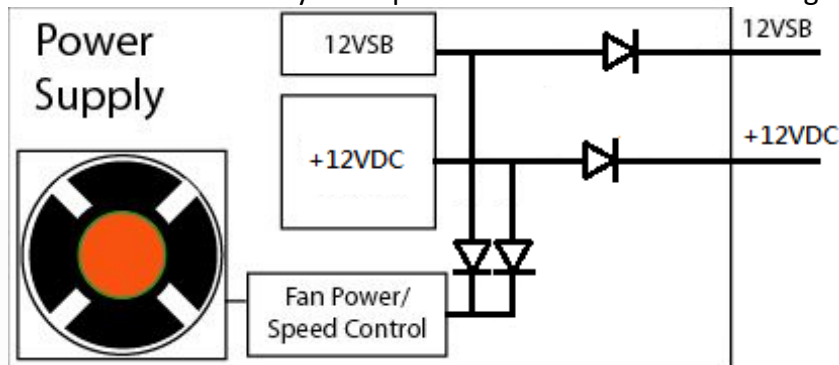

Figure-4 FAN Vcc Topology

Power supply unit shall contain fan speed control circuits to vary the speed so that the critical component temperatures do not exceed safe operating levels. Temperature Sensors are to be located on a critical primary component and a critical secondary component. Power supply unit design shall employ PWM control technique to vary fan speed for maintaining hot spot components within reliable limits. When the power supply unit is in standby mode (no +12VDC is present), the fan shall operate at 3500 rpm around to maintain component reliability at all Standby-load, all specified input voltage condition and any operating environmental requirements. For fan speed chart, please refer to FW spec.

4.5 Timing

These are the timing requirements for the power assembly operation. The output voltages must rise from 10% to within regulation limits (T_{vout_rise}) within 0 to 20ms. The +5V, +3.3V and +12V output voltages should start to rise at about the same time. All outputs must rise monotonically. The +5V output needs to be greater than the +3.3V output during any point of the voltage rise. The +5V output must never be greater than the +3.3V output by more than 2.25V. Each output voltage shall reach regulation within 50 ms (T_{vout_on}) of each other during turn on of the power supply. Each output voltage shall fall out of regulation within 400 ms (T_{vout_off}) of each other during turn off. Figure 1 and figure 2 show the turn On and turn Off timing requirement. In Figure 2, the timing is

shown with both AC and PSON# controlling the On/Off of the power supply.

Table-13 Timing Requirements

Item	Description	Min.	Max.
T _{vout_rise}	Output voltage rise time from each main output.	--	20mSec
	Ouput voltage rise time for the 5VSB output.	--	25mSec
T _{vout_on}	All main outputs must be within regulation of each other within this time.	--	50mSec
T _{vout_off}	All main outputs must leave regulation within this time.	--	400mSec

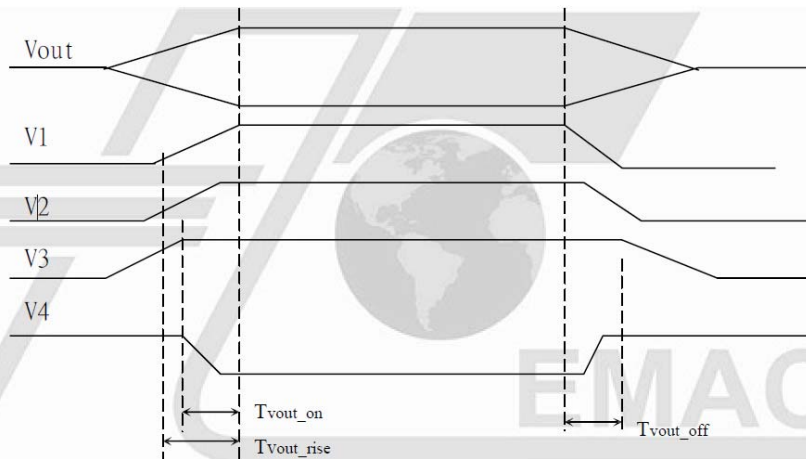

Figure 1: Output Voltage Timing

Item	Description	Min.	Max.
T _{sb_on_delay}	Delay from AC being applied to 5VSB being within regulation.	--	1500mSec
T _{ac_on_delay}	Delay from AC being applied to 12VDC being within regulation.	--	3000mSec
T _{12VDC_holdup}	Delay from loss of AC power to 12VDC out of regulation. (70% of rated load)	10mSec	--
T _{pwok_holdup}	Delay from loss of AC to deassertion of PWOK.	9mSec	--

$T_{pson_on_delay}$	Delay from PSON Active to output voltages within regulation limits.	5mSec	400mSec
T_{pson_pwok}	Delay from PSON# deactive to PWOK begin deasserted.	--	50ms
T_{pwok_on}	Delay from 12VDC within regulation limits to PWOK asserted at turn on.	100mSec	500mSec
T_{pwok_off}	Delay from PWOK deasserted to output voltages (3.3V, 5V, 12V, -12V) dropping out of regulation limits.	1mSec	--
T_{pwok_low}	Duration of PWOK being in the deasserted state during an off/on cycle using AC or the PSON signal.	100mSec	--
T_{sb_vout}	Delay from 5VSB being in regulation to 5VDC being in regulation at AC turn on	50mSec	1000mSec
T_{5Vsb_holdup}	Delay from loss of AC power to 5VSB out of regulation.	1000ms	--

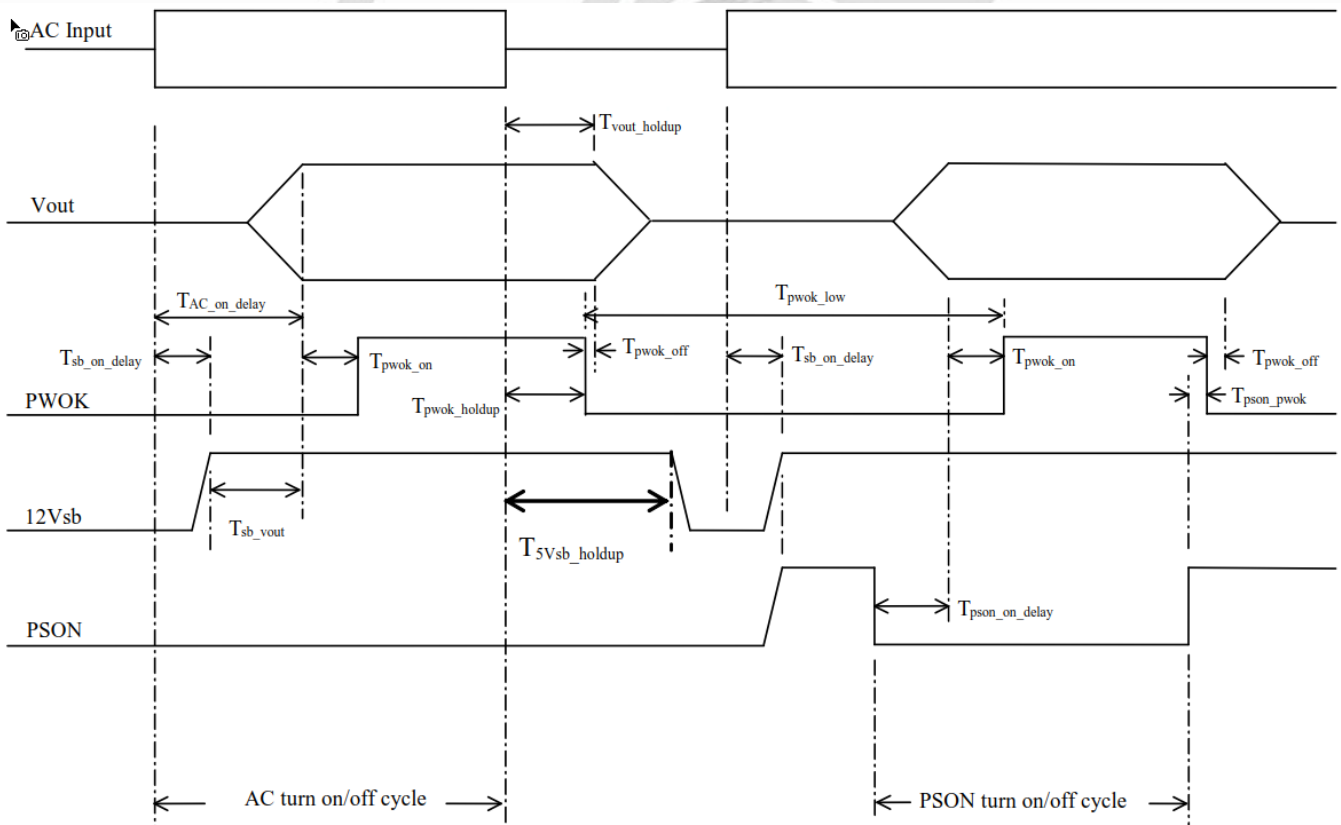

Figure-2 Output On/Off Timing

4.6 Report Accuracy

The electrical signal, Vin, Iin, Vout, Iout, Pin, Pout, temperature and FAN speed should be reported by PMBus communication. Please refer to FW specification for detail information.

- (1) The accuracy is within $\pm 5\%$ for Pin, Vin, Iin, Pout, Vout and Iout at 20%~100% loading at all specified input voltage condition and any operating environmental requirements.
- (2) The accuracy is within $\pm 10\%$ for Pin, Vin, Iin, Pout, Vout and Iout at 10%~20% loading at all specified input voltage condition and any operating environmental requirements.
- (3) The accuracy is within $\pm 10^{\circ}\text{C}$ for ambient temperature at all specified input voltage condition, all specified output load and any operating environmental requirements.
- (4) The accuracy is within $\pm 500\text{rpm}$ for ambient temperature at all specified input voltage condition, all specified output load and any operating environmental requirements.

5.0 Output Protection

5.1 Over Current Protection(OCP)

This power supply shall have current limit to prevent the +5V, +3.3V, and +12V outputs from exceeding the values shown in Table 7. The current limit shall not trip under maximum continuous load or peak loading as described in Table 14. The power supply shall latch off if the current exceeds the limit. The latch shall be cleared by toggling the PSON# signal or by cycling the AC power. The power supply shall not be damaged from repeated power cycling in this condition. The -12V and +5VSB outputs shall be shorted circuit protected so that no damage can occur to the power supply.

Table-14 Over Current Limits

Output Voltage	Minimum	Maximum	Protection Mode
+5V	110%	165%	latch off
+3.3V	110%	165%	latch off
+12V	110%	165%	latch off

5.2 Over/Under Voltage Protection(OVP/UVP)

Over/under voltage protection shall be locally sensed. In +12VDC over or under voltage protection, the +12VDC shall be shut down in latch off mode. This latch shall be cleared by toggling the PSON signal or by AC power recycle. Standby output shall not latch off due to an over/under voltage condition. A fault on main output will not cause the standby to turn off. Also, that fault on standby will cause the other outputs to turn off but not latch.

Table-15 Over Voltage Limits

Output Voltage	Minimum	Maximum	Protection Mode
+5V	+5.7V	+6.5V	latch off
+3.3V	+3.7V	+4.3V	latch off
+12V	+13.5V	+15V	latch off

5.3 Short Circuit Protection(SCP)

A short circuit placed on any DC output to DC return shall cause no damage. The power supply shall be no damage in case any short circuit is taken place at +5V,+3.3V ,+12V ,-12Voutput. The power supply shall be auto-recovered in case any short circuit is taken place at +5VSB.

5.4 Over temperature Protection(OTP)

The power supply shall incorporate a thermal shut down feature that turns off all outputs except standby when an over temperature condition occurs, such as loss of FAN cooling or excessive ambient temperature. The power supply will not be damaged and will return to normal operation after the over temperature condition no longer exists and the power supply has been reset. The OTP trip level shall have a minimum of 5 degree of hysteresis shall be employed to prevent a frequent toggling on/off of the outputs. There are thermal sensors located in the power supply to monitor the inlet temperature and hot spots devices, used for corresponding action when the temperature over its limitation. The power supply shall assert the over temperature warning SMBAlert signal when the inlet operating temperature and internal component reach a warning threshold.

5.5 Over power protection (OPP)

The power supply shall provide over power protection on the power supply latches all DC output into a shutdown state. Over power of this type shall cause no damage to power supply, after over load is removed and a power on/off cycle is initiated, the power supply will restart.

Trigger point total power min. 110%, max. 150%.

6.0 Environment Specification

6.1 Temperature

Operation : 0°C~50°C
Storage : -40°C ~70°C

Maximum rate of change is 10°C/1HR

6.2 Humidity

Operation : 10%~85%
Storage : 10%~95%

6.3 Altitude

- 6.3.1 The power supply can be operated at altitudes from sea level up to 5000 meter maximum.
- 6.3.2 The power supply can be stored at altitudes up to 50,000 feet maximum.

7.0 EMI

7.1 Conducted emission

- 7.1.1 It is refer to CISPR 22 (EN 55032), Class A.
- 7.1.2 Also meet FCC (USA) Part 15, Subpart J, Class A.

7.2 Radiated emission

- 7.2.1 It is refer to CISPR 22 (EN 55032), Class A.
- 7.2.2 Also meet FCC (USA) Part 15, Subpart J, Class A.

7.3 Harmonic Current

- 7.3.1 It is refer to EN 61000-3-2

8.0 EMS

8.1 Electrostatic Discharge (ESD)

- 8.1.1 It is refer to IEC 61000-4-2, EN 61000-4-2.
- 8.1.2 Air Electrostatic Discharge : $\pm 8KV$
- 8.1.3 Contact Electrostatic Discharge : $\pm 4KV$

8.2 Radiated Immunity (RS)

- 8.2.1 It is refer to IEC 61000-4-3, EN 61000-4-3.
- 8.2.2 Radiated Susceptibility : 3V/m

8.3 Transient Burst (EFT)

- 8.3.1 It is refer to IEC 61000-4-4, EN 61000-4-4.
- 8.3.2 EFT Test : $\pm 1KV$

8.4 Surge

- 8.4.1 It is refer to IEC 61000-4-5, EN 61000-4-5.
- 8.4.2 Common mode Surge Immunity : $\pm 1KV$
- 8.4.3 Differential mode Surge Immunity : $\pm 2KV$

8.5 Conducted Radio Frequency Disturbances Test (CS)

- 8.5.1 It is refer to IEC 61000-4-6, EN 61000-4-6.
- 8.5.2 Injected Current Susceptibility : 3Vrms

8.6 Power Frequency Magnetic Field Test

- 8.6.1 It is refer to IEC 61000-4-8, EN 61000-4-8.
- 8.6.2 Magnetic Field Strength : 1A/m

8.7 Voltage Dips, Short Interruptions and Voltage Variations

- 8.7.1 It is refer to IEC 61000-4-11, EN 61000-4-11.

9.0 Safety

9.1 Safety Conforming

9.1.1 Underwriters laboratory (UL).

The power supply designed to meet UL 60950 & UL 62368-1.

9.1.2 Canadian standards association (CUL)

The power supply designed to meet CSA C22.2 No. 60950-1 & No. 62368-1.

9.1.3 TUV

The power supply shall be designed to meet TUV EN-60950-1 & EN-62368-1

9.1.4 CCC Standards

The power supply shall be designed to meet GB9254-2008, GB4943.1-2011, GB17625.1-2012.

9.2 Insulation Resistance

9.2.1 Input to output : 20MΩ at 500 VDC.

9.3 Dielectric Strength (Hi-Pot)

Primary to secondary	: 3000 VAC for 60 sec.
Primary to FG	: 1500 VAC for 60 sec.
For production purpose	:
Primary to FG	: 1500 VAC for 1 sec.

10.0 Reliability

10.1 MTBF

The MTBF of the power supply shall be calculated utilizing the Part-Stress Analysis method of MIL-HDBK-217F.

The calculated MTBF of the power supply is 240276 hours at ambient temperature 25 degree.anical requirements

11.0 Mechanical requirements

Physical dimension : 222mm (D) x 150mm (W) x 86mm (H)