 SWITCHING POWER SUPPLY	<b>PRODUCT SPECIFICATION</b>	File: EA-250SUB-A11
	Model: 250SUB Active PFC F0 Full Range Rev.:A1.1	Date: Jul. 26, 2017 Page: 1 of 6

## 1.0 INPUT:

### 1.1 VOLTAGE

	MINIMUM	MAXIMUM	UNITS
INPUT RANGE	90	264	Vrms
RATED RANGE	100	240	Vrms

### 1.2 FREQUENCY

47Hz ~ 63Hz

### 1.3 CURRENT

5A/100V, 2.5A/240V

### 1.4 INRUSH CURRENT

115V/50A(max.), 230V/100A(max.) at 25°C (cold start)

### 1.5 POWER EFFICIENCY

At 20%/50%/100% load AC 115V 60Hz and AC 230V 50Hz, the power efficiency should be at least 82%/85%/82%.

### 1.6 STANDBY MODE

During measurement of the "STANDBY MODE" condition, the main converter is off (PS\_ON=High). +5Vsb converter is working and standby input power is measured.

Load Condition	Efficiiiency	Power in
<45mA	----	<0.45W
45mA	>=50%	----
100mA	>=55%	
250mA	>=65%	----
1.0A	>=75%	----
<b>*2013 ErP Standby efficiency</b>		

### 1.7 ACTIVE POWER FACTOR CORRECTION (PFC):

PFC at

half/full load:>0.95 at AC 110v 60Hz(typical)

full load:>0.90 at AC 230v 50Hz(typical)

 SWITCHING POWER SUPPLY	<b>PRODUCT SPECIFICATION</b>				File: EA-250SUB-A11	
	Model: 250SUB Active PFC F0 Full Range Rev.:A1.1				Date: Jul. 26, 2017	
					Page: 2 of 6	

## 2.0 OUTPUT:

GROUP	1					2
	+3.3V	+5V	+12V1	+12V2	-12V	+5VSB
MAX.LOAD	14A	17A	12A	12A	0.8A	2.0A
MIN.LOAD	0.1A	0.2A	0.1A	0.5A	0A	0A
REGULATION	±5%	±5%	±5%	±5%	±10%	±5%
RIPPLE & NOISE (mV)	50	50	120	120	120	50
Capacitive Loads_(uF)	10000	10000	10000	10000	330	10000

### NOTE:

- The continuous maximum total output power shall not exceed 250W.  
+12V DC maximum output power shall not exceed 18A(216W).  
+3.3V and +5V DC maximum combined output power shall not exceed 110W.
- Maximum peak total DC output power should not exceed 275W.
- Peak power and current loading should be supported for a minimum of 1 second.
- +3.3V, +5V and +12V DC output voltage should be within Figure 1 cross loading range to meet regulation.
- Ripple and Noise measuring with an oscilloscope with 20 MHz bandwidth in Figure 1 cross loading range. Output should be bypassed at the connector with a 0.1uF ceramic disk capacitor and a 10uF electrolytic capacitor to simulate system load. The length of ground wire on probe should not longer than 40mm, if a Non - differential type of scope was used.

### 2.1 CROSS REGULATION

The +5V & +3.3V combined load and +12VDC load shall remain within the defined in section 2.0 over cross load combinations shown Figure 1:

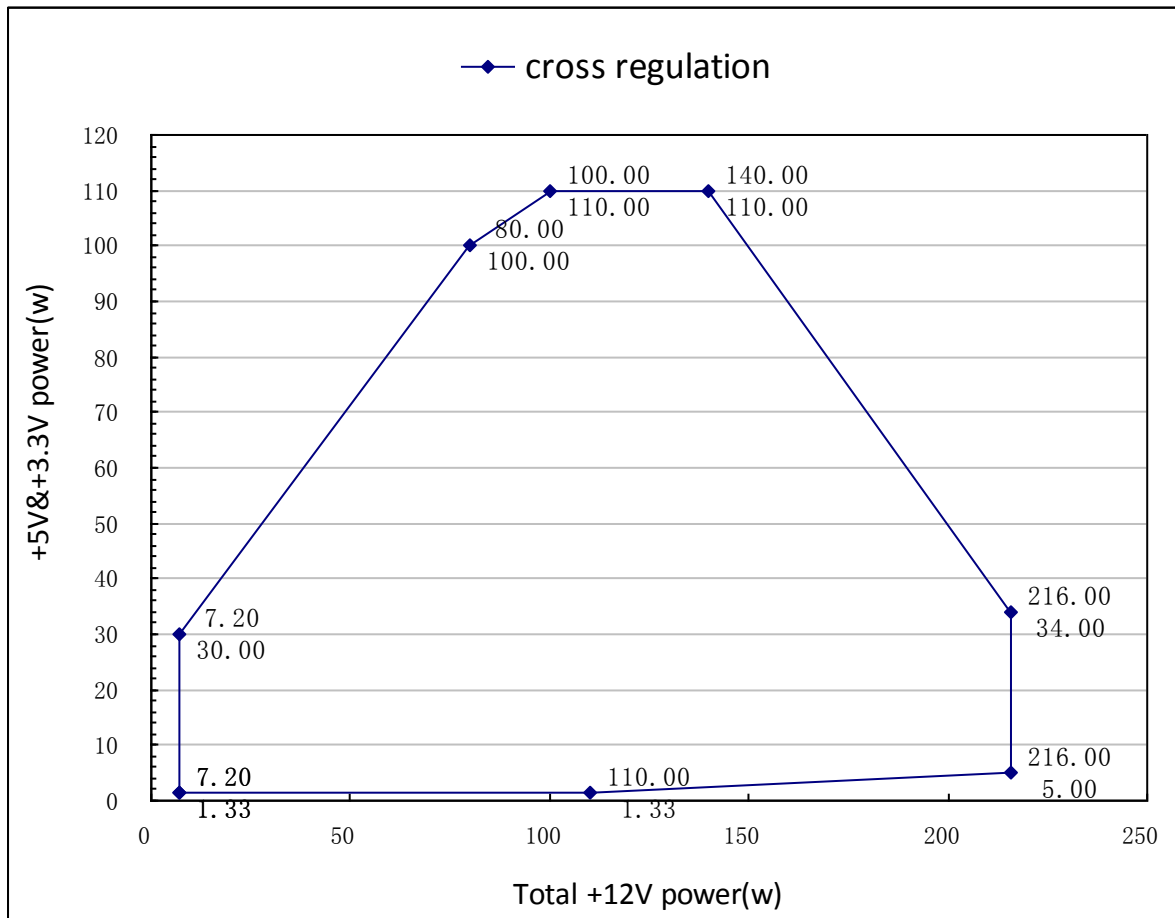

Figure 1

## 2.2 HOLD-UP TIME: 16ms(minimum)

Test Condition: Full load. AC input 115V or 230V, 47Hz .

## 2.3 LOAD TRANSIENT RESPONSE (STEP LOAD)

Step load changes up to 60%(12V) and 30%(3.3V and 5V) of full load, while other loads remains constant within the rating. The load waveform shall be a square wave with the slope of the rise and fall at 1.0A/usec and the frequency shall be from 50Hz to 10kHz. The DC output voltage will stay within regulation of  $\pm 10\%$  during the step load changes.

## 2.4 OVERSHOOT

Overshoot at turn on or turn off shall be less than 10% of the nominal output voltage.

## 2.5 TIMING, HOUSEKEEPING AND CONTROL

A low active PS-ON (DC ON/OFF) input signal is equipped, which provide the interface

**ENABLE** or to **DISABLE** the **GROUP1** of DC output. This signal is electrically to interface with **TTL, OPEN COLLECTOR** and the **HARD SWITCH**.

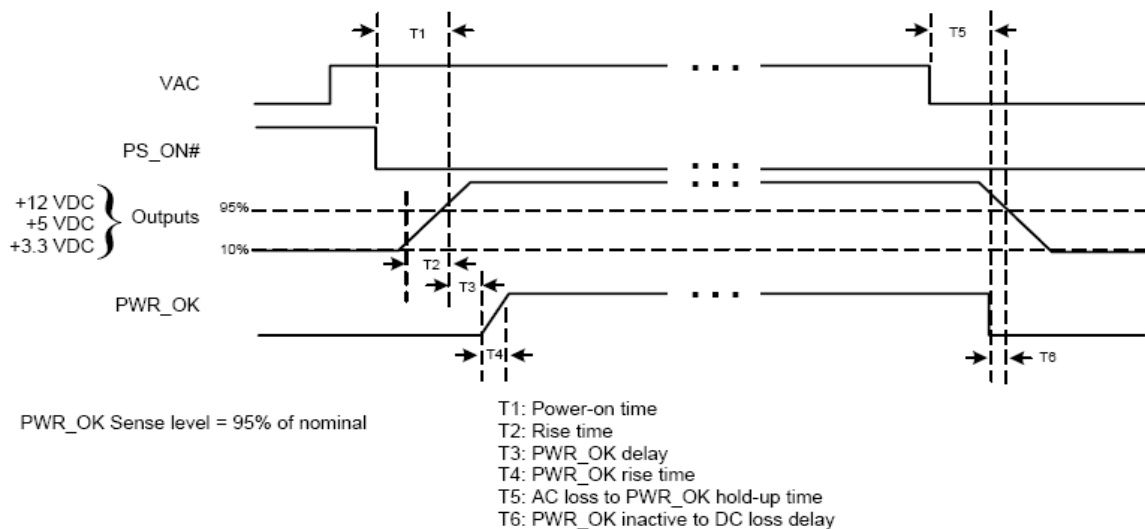

SIGNAL NAME		MAXIMUM	MINIMUM
T1	PS_Power-on time	500mS	
T2	Rise time from each main output	20mS	0.2mS
T3	PWR_ok delay	500mS	100mS
T4	PWR_ok rise time	10mS	
T5	AC loss to PWR_OK hold-up time		16mS
T6	PWR_OK inactive to DC loss delay		1mS

### 2.5.1 POWER GOOD SIGNAL:

Signal Type: open collector +5DC, TTL compatible.

Logic Level: <0.4V while sinking 4 mA.

Logic Level High: between 2.4VDC and +5V output while sourcing 200 uA.

Max Ripple/Noise: 400mV pk-pk. (no capacitor test)

## 3.0 OUTPUT PROTECTION

### 3.1 TOTAL POWER PROTECTION: (OPP)

Total power 140% max with shut-down and latch off protection.

### 3.2 OVER VOLTAGE PROTECTION: (OVP)

OUTPUT VOLTAGE	MAX. ACT. VOLTAGE	RESULT
+3.3V	4.3V	Shut down & Latch OFF The Group 1 DC Output
+5V	7.0V	
+12V	15.6V	
+5Vsb	8.0V	

### 3.3 SHORT CIRCUIT PROTECTION: (SCP)

The short between any output of group 1 will shut down all group1.

The short at group 2 will Shut down both group 1 and group 2.

### 3.4 NO-LOAD SITUATION

No damage or hazardous condition should occur with all the DC output connectors disconnected from the load. The power supply may latch into the shutdown state.

### 3.5 RESET AFTER SHUTDOWN

Whenever the power supply latches into shutdown state due to fault condition on its output, the power supply will return to normal operation only after the fault has been removed and the PS\_ON# has been pulled low again. If the power supply latches into shutdown state due to fault condition on 5Vsb, the power supply will return to normal operation only after the fault has been removed and the power switch(power cord) has been cycled off/on(plugged out/in) with A MINIMUM OFF TIME OF 3 SECONDS.

## 4.0 COOLING OF POWER SUPPLY

A DC fan was equipped to cooling the power supply. This fan may not rotate when loading under 50%.

Fan parameters:

Rated Voltage	12VDC
Dimension	40*40*20(mm)
Air flow	7.36CFM min.
Noise	26.5db(A)

 SWITCHING POWER SUPPLY	<b>PRODUCT SPECIFICATION</b> Model: 250SUB Active PFC F0 Full Range Rev.:A1.1	File: EA-250SUB-A11
		Date: Jul. 26, 2017
		Page: 6 of 6

## 5.0 ENVIRONMENT

### 5.1 OPERATING

AMBIENT OPERATION TEMPERATURE: 0 to 50 °C.

AMBIENT OPERATION RELATIVE HUMIDITY: To 85% relative humidity (non-condensing)

### 5.2 SHIPPING / STORAGE

AMBIENT STORAGE TEMPERATURE:-40 to 85 Deg C

AMBIENT STORAGE RELATIVE HUMIDITY: To 95% relative humidity (non-condensing)

## 6.0 MTBF

Over 100,000 hours at 100% Load and 25 Deg C ambient conditions and 115V~ or 230V~ input voltage, excluding the DC Fan.

## 7.0 EMC

CE Class B

FCC Class B

## 8.0 SAFETY

cUL

TUV

CB

CCC

BSMI

RCM

## 9.0 MECHANICAL

Dimension: W 150mm x L 81.5mm x H 40.5mm.